

# Twin Impeller Shower Pump

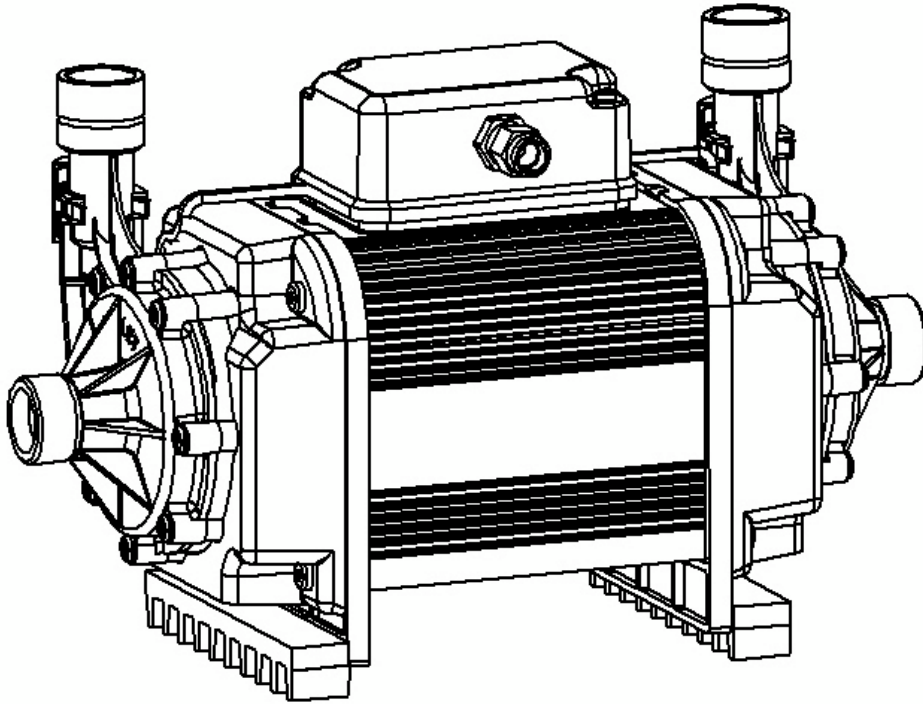

## CENTRIFUGAL SHOWER PUMP MODEL: 2.0 bar Twin

Technical Data			
<b>Electrical</b>			
Volts / Phase / Frequency: 230 / 1 / 50.			
Power Consumption: 350W.		Rated Current: 1.8A.	
Enclosure: IPX2 when mounted on a flat horizontal surface.		Motor: Universal.	
Rating: 20 min on / 40 min off (at flow rates between 5 and 20 l/min).			
<b>Mechanical</b>			
Inlet Head (min – max): 2 – 10m.		Max Developed Pump Head: 20m.	
Max Working Pressure: 3 bar.		Min Starting Flow Rate: 0.5 l/min.	
<b>Dimensions</b>			
Length: 305mm.	Width: 120mm.	Height: 185mm.	Weight: 3.3kg.
<b>Noise</b>			
The sound pressure level 1m from the pump is less than 70dBA.			
<b>Pipework</b>			
All pipework from the cold water storage tank and hot water cylinder to the pump and from the pump to the shower must be a minimum of 22mm diameter.			

## Strainer Installation

The strainers supplied with the pump must be fitted between the pump inlet port and the inlet hose.

The plain hose washers supplied with the pump must be fitted between the pump outlet port and the outlet hose.

The inlet ports are on the end of the pump and the outlet ports are on the top of the pump.

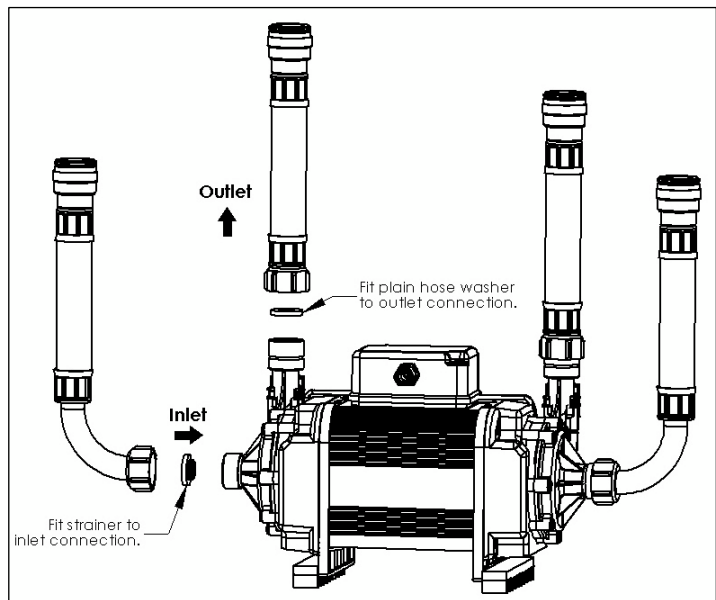

## ONLINE HOME RETAIL LTD. WARRANTY

Online Home Retail Ltd. warranty the parts and workmanship of this product for a period of **two years** from the date of initial purchase, provided that the product is installed and operated in accordance with our instructions and has not been damaged or abused.

The warranty is limited to product repair or replacement only.

This warranty does not affect your statutory rights.

### WARRANTY CLAIM PROCEDURE

If you believe the product is not operating correctly, phone the helpline number

**0845 2000 914**

Most problems with pumps can be eradicated by adjustments to the pump or installation. Please have to hand your: **Proof of purchase, Pump type** (to be found on top label) and **Pump serial number** (to be found on top label).

**DO NOT REMOVE THE PUMP FROM ITS INSTALLATION AS THIS WILL INVALIDATE THE WARRANTY.**

A large percentage of pumps removed from site and returned to us work perfectly when tested in our laboratory. This makes it very difficult for us to help you solve the problem long term. Sometimes the product is just not suitable for the application. It helps us to help you if we can obtain details of the application.

If an engineer's site visit call is required there must be an adult on site during the visit. Site visits to products malfunctioning that are covered by the terms of this warranty will be provided free of charge. Site visits to products outside the terms of this warranty will be on a chargeable basis for parts and labour and must be paid for before or at the time of the site visit.

### Declaration of Conformity

We Online Home Retail Ltd. declare under our sole responsibility that the product 2.0 bar shower pump to which this declaration relates, is in conformity with the Council Directives on the approximation of the laws of the EC Member States relating to

- Machinery (98/37/EC).
- Electrical equipment designed for use within certain voltage limits (2006/95/EC). Standards used: EN60335-1:2002 and EN 60335-2-41:2003.
- Electromagnetic compatibility (2004/108/EC).

Online Home Retail Ltd.  
Millennium House, Vale Link, Vale Park, Evesham, Worcs. WR11 1GR.

Service Helpline: 0845 2000 914.